

# Model of Good Corporate Governance Implementation for Medium, Small and Micro Business Enterprises on East Java

Wisnu Panggah Setiyono\*, Rita Ambarwati Sukmono and  
Niko Fediyanto

**Abstract---** *This study aims to determine the fit model of the implementation of good corporate governance on MSME's of East Java province. This study uses quantitative methods with questionnaires as a data collection tool that is distributed to respondents. The population of this study is all MSME's in Sidoarjo, Surabaya, Malang and Madiun. The sampling technique used a purposive sampling technique so that it gets 150 respondents especially for medium enterprises. The data were analyzed using Structural Equation Modeling (SEM) with AMOS program version 21.0. This research uses an exogenous variable (X) that is good corporate governance implementation and preparation of the financial statement, and endogenous variable (Y) business performance. The results of this study with SEM analysis indicate that good corporate Governance has a significant effect on business performance. Whereas the preparation of financial statements has no significant impact on business performance*

**Keywords---** *Business Performance, Good Corporate Governance Implementation, Preparation of Financial Statements, Structural Equation Modelling (SEM), MSME's.*

---

## I. INTRODUCTION

MSME is a micro small and medium business that plays an important role in developing the national economy, income distribution, expansion of employment opportunities and improving the welfare of the community[1]. Although MSMEs have a strategic role, developing their performance is not an easy matter[2]. Difficulties in measuring performance are one of the problems for MSME actors in evaluating performance due to the lack of MSME actors' attention to the preparation of financial statements[3]. MSME entrepreneurs pay more attention to their operational activities so that they often ignore accounting records and financial reporting[1]. Good financial performance and good corporate governance practices will make MSMEs manage finances and develop the business more easily[4][5]. Knowledge, ability and also attachment are fundamental for managing MSMEs. The development of financial literacy will affect MSME activities, especially in terms of funding, both in the production and marketing departments because MSMEs that do not have literacy about finance will be constrained in terms of filing loans from banks[6][1]. The problem faced by MSMEs, particularly the small medium enterprises, is the lack of the role of control in preparing and managing finances that can later be used as the main reference in making financial decisions and supporting business performance. This study aims to examine the appropriate structural model of GCG practices and financial statement preparation on the performance of MSMEs.

---

Wisnu Panggah Setiyono\*, E-mail: wisnu.umsida@gmail.com  
Rita Ambarwati Sukmono,  
Niko Fediyanto

## II. METHOD

This research uses a quantitative method, which is a research method based on the philosophy of positivism, which is used in researching certain populations and samples[7][8]. Data was collected using a quantitative/statistical data analysis research instrument, which aims to test the hypotheses that have been set[9].

### *Location*

This research was carried out in the five Districts of East Java Province including Sidoarjo, Surabaya, Pasuruan, Malang and Madiun which focused on Medium enterprises. These five locations were chosen because they are most of the residents are as producers of the medium enterprises, which is one of the leading MSME products in East Java.

### *Variables*

Table 1: Variable dan Indikator

No	Variable	Indicator
1	Good Corporate Governance Proxies	<i>Separation of agen-principal; Control; and insider Ownership</i> [3][10]
2	Preparation of financial statements	Memory and recording; conceptual speed and verbal understanding; inductive, deductive, and reasoning visualization of space[4][5][11][12]
3	MSME performance	Product; marketing; and finance[13][14][15]

*Source: processed data*

### *Sample and Population*

The population is the whole subject of research while the sample is a part of the population that is represented as a benchmark for drawing conclusions as applicable to the population[16]. In this study, the population in this study was all business people or MSME producers in several distric of East Java Province. Based on the results of a survey from the cooperative and MSME services, as well as the East Java Industry and Trade Office, it can be seen that there are approximately 30,000 MSME units. To take samples, researchers used probability sampling techniques with purposive sampling[7]. The purposive sampling technique was chosen because the researcher has special criteria so that the samples taken will be in accordance with the research objectives and can provide a more representative value[9]. The conditions used are MSMEs[17].

### *Data Type and Data Collection*

The data in this study, which are primary data from MSMS entrepreneurs, were collected using a questionnaire or questionnaire—adata collection technique by giving questions or written statements to respondents to be answered[17][16]. The questionnaire in this study contains questions related to independent variables, namely regarding abilities, skills, and knowledge[18]. These variables are measured using a Likert scale. Likert scale is used to measure income, attitude, and perception of a person or group of social phenomena[16].

### *Data Analysis Technique*

Data analysis techniques in quantitative research use statistics using Structural Equation Modeling (SEM) with the help of the AMOS application program[9][7]. The data analysis technique used is descriptive statistical techniques[9].

Descriptive statistics is a statistical technique used in analyzing data by describing data that has already been collected, as it is without aiming at making conclusions that are applicable in general[7]. Structural Equation Modeling (SEM) is a statistical technique to analyze the pattern of relationships between latent constructs and their Indicators, latent contracts with each other, and direct measurement errors[7].

The suitability of the model is evaluated through a review of the Goodness of fit criteria. Data are evaluated to meet SEM assumptions[19].

#### *a. SEM assumptions*

1. The minimum sample size in SEM is 100.
2. Normality and Linearity
3. Assuming normality in SEM can use the value c.r with a range of values between -2.58 to +2.58 so that the data can be declared normally distributed
4. Outliers are data that have unique characteristics that look different from other data and appear extreme values for either a single variable or a combination variable.
5. Multicollinearity and singularity. Multicollinearity can be determined from the determinant of the covariance matrix. The small determinant value of the covariance matrix indicates the presence of multicollinearity or singularity.

#### *b. Validity and Reliability Tests*

Validity test is used to test the validity of research instruments. Validity is a measure that indicates the level of validity of the instrument. The instrument is said to be valid if it is able to measure the desired thing[16].

Validity testing in research uses convergent validity by looking at the value of the loading factor. The standardized loading factor value must be equal to 0.50 or more ideal should be 0.70. If the loading factor value is still below 0.50 then for further analysis the Indicator must be discarded[16].

#### *c. Model Assessment*

Some indices to measure the degree of concordance between the hypothesized model and the data presented are as follows.

Table 2: Goodness of fit index

<b>Goodness of Fit Index</b>	<b>Cut off Value</b>
Chi-Square Statistic	Expected to be small
CMNDF	$\leq 2,0$
GFI	$\geq 0,90$
AGFI	$\geq 0,90$
RMSEA	$\leq 0,08$
TLI	$\geq 0,95$
CFI	$\geq 0,95$

Source: [6]

## 6. Hypothesis Test

The hypothesis in this study was tested using SEM. Hypothesis testing in SEM there is two types, hypothesis testing models and testing hypotheses about the causality relationship[19]. Testing the hypothesis of the model using a probability value of  $\geq 0.05$ . Model hypotheses can be tested using goodness of fit.

## III. RESULT AND DISCUSSION

### 1. Assumption Test

Testing assumptions in SEM using the assumptions test for normality, linearity, multicollinearity, and singularity[19]. Assumption tests are carried out using AMOS version 21.

#### Normality Test

Normality assumption test results obtained from the AMOS output has a c.r value of 5.233 indicating that the data are not normally distributed because the data is said to be normally distributed if the normality value is between -2.58 to +2.58.

#### Linearity Test

Outlier data is data whose value is far above or below the average data value. Mahalanobis distance value is used to find outlier data. A data is said to have outliers if  $p_1$  and  $p_2 < 0.05$ .

#### Multicollinearity Test

The multicollinearity test is indicated by a warning from the AMOS application. Based on this, if there is no warning when analyzing, then there is no multicollinearity of data.

The Elimination of outlier data output results on AMOS based on mahalanobis distance is done to meet the SEM assumptions that have not been met, such as normally distributed data and the presence of outliers. After the outlier data is deleted and re-estimated, the results of the linearity test on the AMOS output show that there is no outlier data and the data is normally distributed with a c.r value of 2.167.

### 2. Validity

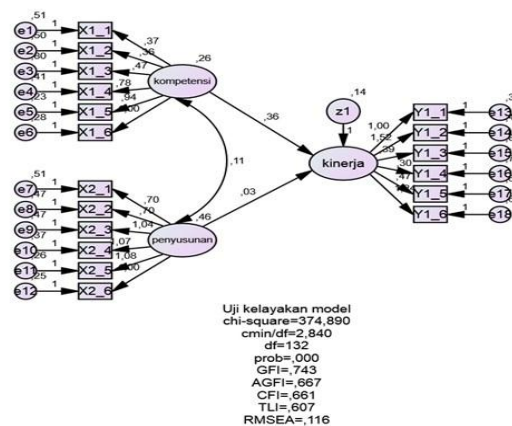

Figure 1: Research Model

Source: processed data wis Amos 21.0 (2019)

Table 3: Standardized Regression Weights

	Estimate	Description
X1.6 <-- GCG practices	,694	Valid
X1.5 <-- GCG practices	,699	Valid
X1.4 <-- GCG practices	,526	Valid
X1.3 <-- GCG practices	,256	invalid
X1.2 <-- GCG practices	,250	invalid
X1.1 <-- GCG practices	,254	invalid
X2.6 <-- Financial reporting	,805	Valid
X2.5 <-- Financial reporting	,823	Valid
X2.4 <-- Financial reporting	,767	Valid
X2.3 <-- Financial reporting	,717	Valid
X2.2 <-- Financial reporting	,568	Valid
X2.1 <-- Financial reporting	,553	Valid
Y1.1 <-- MSME performance	,564	Valid
Y1.2 <-- MSME performance	,695	Valid
Y1.3 <-- MSME performance	,173	invalid
Y1.4 <-- MSME performance	,142	invalid
Y1.5 <-- MSME performance	,232	invalid
Y1.6 <-- MSME performance	,531	Valid

Source: Processed Data (2019)

The indicator can be said to be valid if the value of the standardizer loading estimation is equal to 0.50 or ideally should be 0.70. Invalid contract indicators must be excluded from the analysis as a condition for continuing further testing. Except Variable preparation of financial statements because Variable preparation of financial statements is an exogenous variable. The results of issuing an Indicator are not as follows:

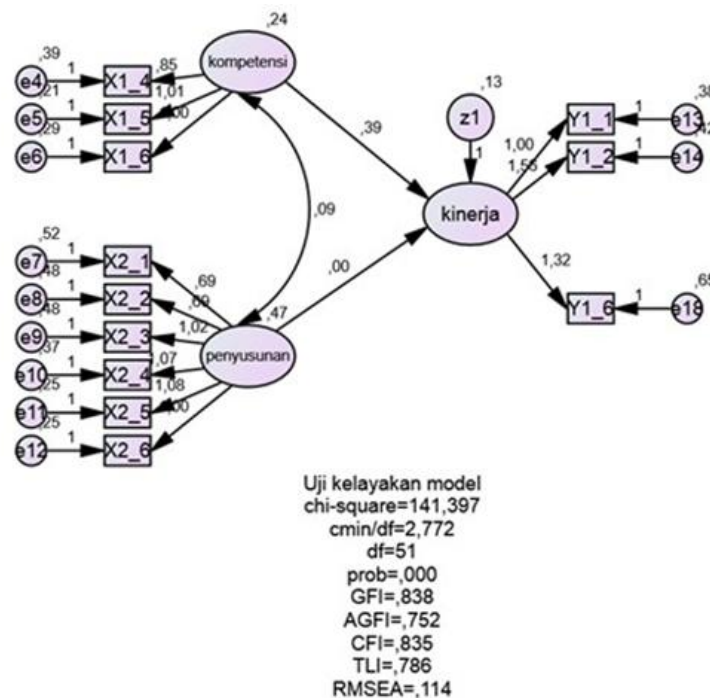

Figure 2: Research model after invalid indicator being eliminated

Source: Data was processed with Amos 21.0 (2019)

Table 4: Standardized Regression Weight (after invalid Indicator were eliminated)

			Estimate	Description
X1.6	<--	GCG practices	,676	Valid
X1.5	<--	GCG practices	,733	Valid
X1.4	<--	GCG practices	,554	Valid
X2.6	<--	financial_reporting	,810	Valid
X2.5	<--	financial_reporting	,827	Valid
X2.4	<--	financial_reporting	,767	Valid
X2.3	<--	financial_reporting	,711	Valid
X2.2	<--	financial_reporting	,564	Valid
X2.1	<--	financial_reporting	,547	Valid
Y1.1	<--	MSME Performance	,554	Valid
Y1.2	<--	MSME Performance	,701	Valid
Y1.6	<--	MSME Performance	,558	Valid

Source: processed using Amos 21.0 (2019)

Validity Value of each Indicator can be seen that all instruments used to measure the research Indicator are declared valid, can be seen from the estimated values above 0.50, match with the limits of convergent validity.

### 3. Reliability

Reliability is an instrument that is trusted as a data collection tool because the instrument is good which can be tested with the following formula:

$$construct\ Reliability = \frac{(\sum Std. Loading)^2}{(\sum Std. Loading)^2 + \epsilon.j}$$

Description :

Std. Loading = standarized loading of each Indicator

$\epsilon.j$  = measurement error of each Indicator

The reliability value of the instrument in the SEM reliability test is more than equal to 70% ( $\geq 0.70$ ) [20]. The instrument is said to be reliable if the reliability value is more than equal to 70% ( $\geq 0.70$ ). If the reliability range of 60% - 70% (0.60 - 0.70) can still be accepted with the terms of the validity of the Indicator in a good model. The reliability test results for each variable are as follows.

Table 5: Construct Reliability

Construct	$\Sigma$ Standarized Loading	$(\Sigma$ Standarized Loading) <sup>2</sup>	$\Sigma \epsilon.j$	Reliabilitas	Keterangan
GCG practices	1,963	3,853	1,699	0,694	Reliabel
Finacial Reporting	4,226	17,859	2,949	0,858	Reliabel
Work Performance	1,813	3,287	1,890	0,635	Reliabel

Source: processed data(2019)

#### 4. The goodness of the FitModel Test

The model in SEM is assessed by how far it is in adjusting the hypothesis of the model is sufficient to explain the existing sample data[20]. This test is carried out to find out how they fit the model with the research data obtained.

Based on the analysis conducted, it can be seen the results of the output of the goodness of fit test are as follows:

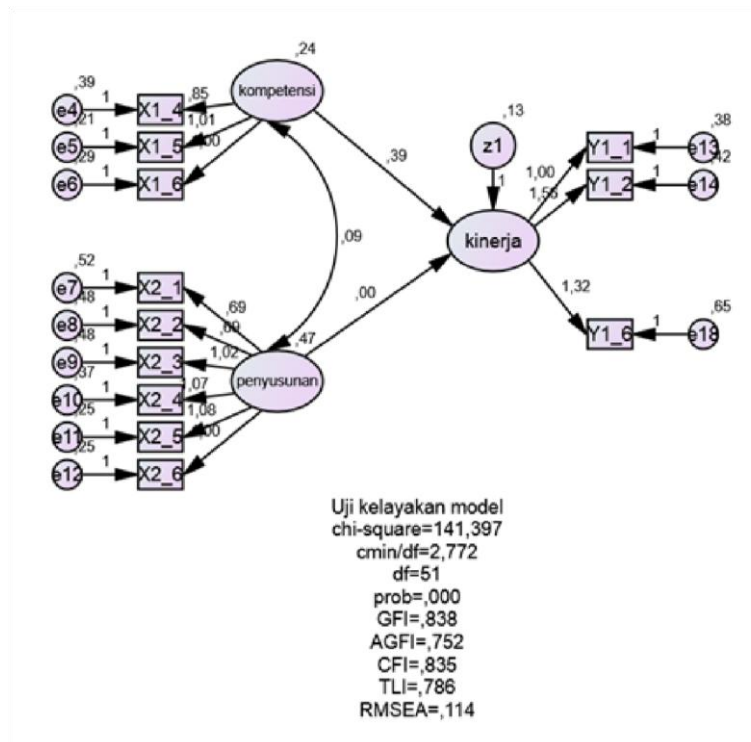

Figure 3 Diagram Output of Early SEM Trajectory Model

Source: data processed with Amos 21.0 (2019)

Table 6: Goodness of fit early model test result

Goodness of Fit Index	Cut off Value	Score in research	Description
Chi-Square Statistic	Expected to be low	141,397	
CMNDF	≤2,0	2,772	Poor fit
Probabilitas	>0,05	0,000	Poor fit
GFI	≥0,09	0,838	Poor fit
AGFI	≥0,09	0,752	Poor fit
RMSEA	≤0,08	0,114	Poor fit
TLI	≥0,95	0,786	Poor fit
CFI	≥0,95	0,835	Poor fit

Source: processed data(2019)

Based on the results of the Goodness of fit test model in Table 4.13, it was concluded that the model was not fit with the study because it still did not meet the recommended Goodness of fit model, so the research needed a model modification.

5. Modifications Model

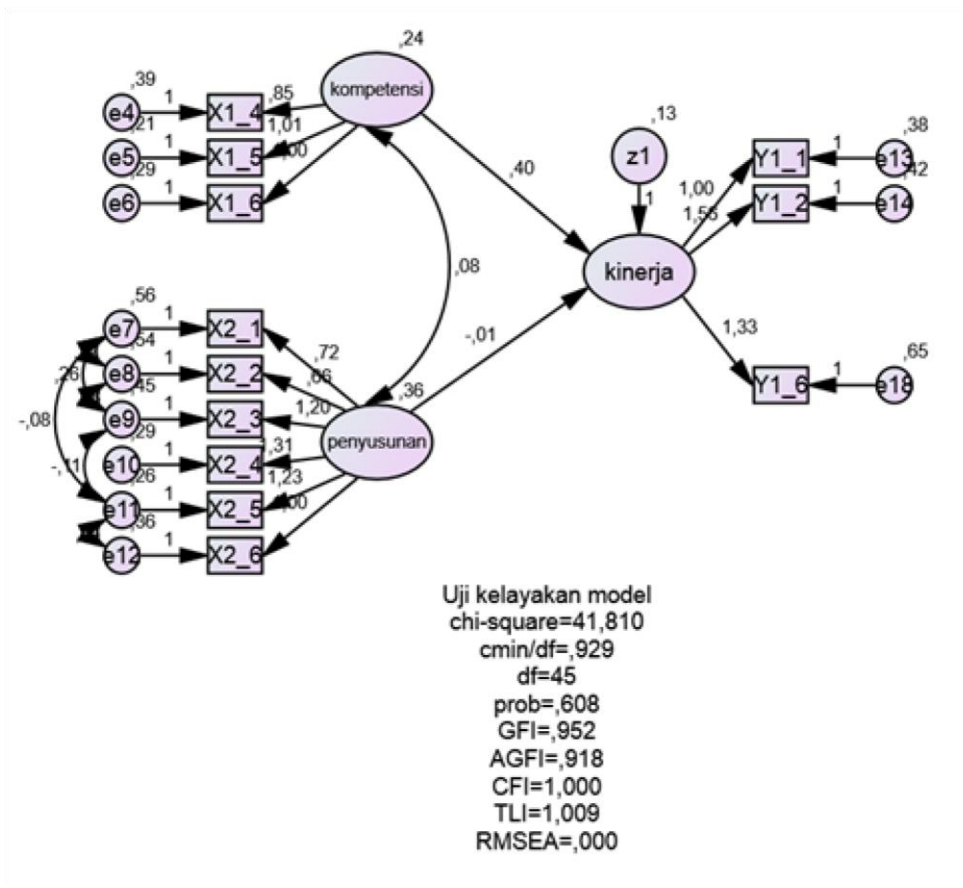

Figure 4: Output SEM model trajectory diagram modification

Source: data processed with Amos 21.0 (2019)

Table 8: Goodness of fit modification model test result

Goodness of Fit Index	Cut off Value	Score in research	Description
Chi-Square Statistic	expected to be small	41,810	
CMNDF	≤2,0 0,929		Good fit
Probabilitas	>0,05	0,608	Good fit
GFI	≥0,90	0,952	Good fit
AGFI	≥0,90	0,918	Good fit
RMSEA	≤0,08	0,000	Good fit
TLI	≥0,95	1,009	Good fit
CFI	≥0,95 1,000		Good fit

Source: processed data(2019)



## 6. Hypothesis Test

After the SEM Model fit hypothesis testing can be done, hypothesis testing is done by observing the value of C.R. (critical ratio) contained in the AMOS Table regression weight output.

Table 9: Regression Weights

		Estimate	S.E.	C.R.	P	Label
MSME performance	<--- GCG practices	,395	,133	2,961	,003	par_10
MSME performance	<--- Financial reporting	-,009	,079	-,119	,905	par_11

Source: processed data

Hypothesis testing is conducted by comparing the value of C.R. in the table with a critical value that is identical to the t-value, which is 1.65 at a significance level of 5%. If the value of C.R. greater than the critical value with a significance level of  $p < 0.05$ , then the hypothesis is rejected. From the results of this output, this can be interpreted that GCG Practices have a significant influence and have a positive distribution on the performance of MSMEs. Meanwhile, the preparation of financial statements does not have a significant effect on the performance of MSMEs.

Based on the results of research, we found that:

### 1. Effect of Good Corporate Governance practices on Business Performance

The results of the data output of this study are known to have a C.R value of 2.961. This value is greater than the critical value, which is 1.65. Therefore, it can be concluded that  $H_0$  is rejected and  $H_a$  accepted, which means that the data shows that there is a positive and significant influence of GCG practices on business performance. The more implemented of GCG practices on medium enterprises are, the better the business performance will be. This result inline with previous studies and are also supported by the results of field surveys. As the results of research from Jaswadi[14][12] where GCG implemented on SME's has a significant positive effect on MSME Performance. Because the implementation of good corporate governance in their fields is able to make a big influence on what they are doing[21][22][23]

### 2. Effect of Preparation of Financial Statements on Business Performance

The results of the data output of this study are known to have a C.R value of -0.119. This value is much smaller than the critical value, which is 1.65. so, it can be concluded that  $H_a$  is rejected and  $H_0$  is accepted which means the data shows that the preparation of financial statements does not have a significant effect on the performance of the SMEs[24][14].

The results of this study are supported by several previous studies that business performance is not affected by the preparation of financial statements, such as the results of research conducted by Nurlaela (2015)[25] which states that the preparation of financial statements has no significant effect on the performance of the SMEs[5][10]. However, if the preparation of the financial statements is good, it is likely to make the effort that was initially difficult to make loans at the bank now younger. While in real terms through a survey conducted by researchers the several districts of East Java Province. Most business actors simply record the transactions that occur without accounting books that are good and right, but this does not affect the performance of the venture effort. The proof is

that even without the financial statements the entrepreneurs are able to produce a large turnover and are able to distribute their homemade goods outside the island.

#### IV. CONCLUSION

Based on the results of research that has been done, then this can be drawn a conclusion that:

1. This study aims to find a fit model of the influence of GCG practices, and Financial Report Preparation on Business Performance conducted in East Java Province located in Sidoarjo, Surabaya, Pasuruan, Malang and Madiun. This research is shown in the SEM fit model output.
2. The analysis shows that GCG practices has a positive influence on improving business performance by 0.395 or 39.5%. However, the Indicator of insider ownership has the lowest impact among other Indicators of the good corporate governance practices.

The analysis of the research shows that the preparation of financial statements does not have a significant influence on improving business performance, according to the results of field research which proves that the business of employees with employees who exceed 50 employees and their businesses increase rapidly but does not provide financial reports.

#### REFERENCES

- [1] Bank Indonesia, "Profil Bisnis Usaha Mikro, Kecil dan Menengah (UMKM)," 2015.
- [2] W. P. Setiyono and L. Ernawati, "Risk Management, Working Capital Management and Financial Performance," vol. 1, no. 2, pp. 91–98, 2017.
- [3] S. Ardiana, I.A. Brahmayanti, "Kompetensi SDM UKM dan Pengaruhnya Terhadap Kinerja UKM di Surabaya," *J. Manaj. dan Kewirausahaan*, vol. 12, no. 1, pp. 42–55, 2010.
- [4] J. Abor and C. K. D. Adjasi, "Corporate governance and the small and medium enterprises sector : theory and implications," vol. 7, no. 2, pp. 111–122, 2007.
- [5] W. L. Tan and T. M. Tan, "The Impact of Corporate Governance on Value Creation in Entrepreneurial Firms," 2004.
- [6] D. C. Mueller, "Corporate Governance and Economic Performance," *Int. Rev. Appl. Econ.*, vol. 20, no. 5, pp. 623–643, 2006.
- [7] Damodaran Gujarati, *Econometrics By Example*, First. Palgrave Macmillan, 2014.
- [8] R. L. T. & W. C. B. Hair, J.F. Jr; R.E. Anderson, *Multivariate Data Analysis With Readings*. Eaglewoods Cliffs, NJ: Prentice Hall Inc., 1995.
- [9] W. Hair, JF, Anderson, RE, Tatham, RL & Black, *Multivariate Data Analysis*, 7th ed. New Jersey: Prentice-Hall International, Inc., 2010.
- [10] O. Kraja, "Competitive Advantage and its Impact in Small and Medium Enterprises (SMEs) (Case of Albania)," *Eur. Sci. J.*, vol. 9, no. 16, 2013.
- [11] W. P. Setiyono and D. Irawaty, "Gender diversity 's board structures, ownership structure and corporate performance in Indonesian," in *International Conference Education and Social Sciences (ICEASS)*, 2016.
- [12] A. Purmerend, "Good corporate governance pays off for Indonesia," *The Jakarta Post*, 2012.
- [13] J. G. Zahra, S. A., & Covin, "Contextual influences on the corporate entrepreneurship-performance relationship: A longitudinal analysis," *J. Bus. Ventur.*, vol. 10, no. 1, pp. 43–58, 1995.
- [14] J. Jaswadi, "Analisis tingkat implementasi good corporate governance pada usaha kecil dan menengah," *J. Siasat Bisnis*, vol. 20, no. 2, pp. 161–180, 2017.
- [15] M. Rofina and M. P. Priyadi, "Pengaruh Penerapan Good Corporate Governance Terhadap Kinerja Keuangan Perusahaan Di Bei," *J. Ilmu Ris. Akunt.*, vol. 2, no. 1, 2013.
- [16] L. Gravetter, F & Wallnau, *Statistics for the behavioral sciences*, First. Belmont, California: Thompson Learning, Inc., 2007.
- [17] BPS, *PDRB Provinsi Jawa Timur*. 2018, p. 1.
- [18] L. J. Moleong, *Metodologi Penelitian Kualitatif (Edisi Revisi)*, Revisi. Bandung: Remaja Rosdakarya,

- 2017.
- [19] Dkk Ghozali Imam, *Structural Equation Modeling Teori Konsep, dan Aplikasi dengan Program Listrel*, First. Semarang: Universitas Diponegoro, 2008.
- [20] Santoso, *Structural Equation Modeling Concept and Applications with AMOS*, First. JAKARTA: PT Elex Media Komputindo, 2007.
- [21] I. D. K. R. Ardiana and I. A. Brahmayanti, “Kompetensi SDM UKM dan Pengaruhnya Terhadap Kinerja UKM di Surabaya,” 2003.
- [22] F. C. G. of Indonesia, *Corporate Governance*, II. Jakarta, 2006.
- [23] H. Patrick, “Corporate governance and the Indonesian financial system: A comparative perspective,” *Pap. CSIS-Columbia Univ. Jt. Res. Progr. Indones. Econ. Inst. Build. a Glob. Econ.*, vol. 1, no. . USAID-Partnership for Growth Project (August)., 2001.
- [24] A. Singh, “Competition, corporate governance and selection in emerging markets,” *Econ. J.*, vol. 113, no. 491, p. F443–F64., 2003.
- [25] S. Nurlaela, “KEMAMPUAN MENYUSUN LAPORAN KEUANGAN USAHA DI KABUPTEN SUKOHARJO,” *Paradigma*, vol. 12, no. 02, pp. 50–59, 2015.