

IOP Publishing

by Dwi Hadi

Submission date: 21-Sep-2023 09:11PM (UTC+0700)

Submission ID: 2172595615

File name: IOP_Publishing.pdf (843.94K)

Word count: 2309

Character count: 11094

PAPER · OPEN ACCESS

SMS Application in bird feed scheduling automation

11

To cite this article: D H R Saputra *et al* 2019 *J. Phys.: Conf. Ser.* **1402** 044008

6

View the [article online](#) for updates and enhancements.

You may also like

4

- [Lift calculations based on accepted wake models for animal flight are inconsistent and sensitive to vortex dynamics](#)
Eric Gutierrez, Daniel B Quinn, Diana D Chin et al.

2

- [A novel hypothesis for how albatrosses optimize their flight physics in real-time: an extremum seeking model and control for dynamic soaring](#)
Sameer Pokhrel and Sameh A Eisa

7

- [Long migration flights of birds](#)
Mark Denny

SMS Application in bird feed scheduling automation

D H R Saputra*, S Syahririni, A Ahfas and J Jamaaluddin

Electrical Engineering Study Program, University of Muhammadiyah Sidoarjo,
Sidoarjo, Indonesia

*dwihadidjaja1@umsida.ac.id

Abstract. With the SMS application, it can be used as a medium for automation of bird feed scheduling, so that poultry farmers are easier to feed birds. Scheduling bird feed can be done continuously, with the aim of avoiding excessive amounts of feed. This application works according to the specified time of the bird owner. This application uses a servo motor to open and close the bird feed reservoir valve, the Microcontroller system as the main controller, SIM800L as a provider of information in the form of SMS, and RTC as a time scheduling system. Bird feed scheduling can be done per second. GSM is used to notify the owner when the system is running. Signal factors during experiments using GSM depend on bad weather or signals tend to be difficult when sending information to bird owners. The process of a servo motor with an angle of opening and closing itself between 0°-90° with a delay time of 50 seconds. For SIM800L a voltage between 3.8-3.9 volts is needed.

1. Introduction

Birds are animals that are kept in cages, the time for feeding birds to be able to lay eggs stable requires regular and continuous bird feed. Caring for birds is a business that is in great demand by the community. There are a number of obstacles faced in bird care, while traveling for a long time. How to provide bird feed continuously and scheduled without having to interfere with daily activities while traveling. In addition to continuous feeding, there is also a need for lighting that function for night lighting if the lights go out. When the lights go out, it can cause birds to take longer or longer to lay eggs because lighting causes an increase in feed consumption [1]. To maintain the continuity of bird feeding, a bird feed scheduling automation system is needed.

The scheduling and work order machines use the NP-hard scheduling method without the setup time [2]. The basis of the success of breeding depends on the provision of feed on time, the amount and quality specified. Scheduling machines can function properly and provide information about the appearance of the owner via SMS [3]. Automation exists in all sectors of human activity. Automation of feeding has been carried out research for pigs or poultry [4]. The SIM800L GSM network (GSM Module) can provide a reprogrammed system connected telephone calls directly to recipients anywhere in the world [5]. With an automated system for Scheduling Bird Feed using a microcontroller in combination with an SMS gateway, it is expected to be more efficient [6-8]. The process of opening and closing bird feed scheduling using infrared sensors and motors automatically. Addition of RTC DS1307 as a timer for timely feeding [9-11].

This study implements a microcontroller as an automation of Scheduling Bird Feed displayed in the form of SMS. With the aim when left behind traveling can provide bird feed continuously by using



DS137 RTC and SIM800L for timing. With the intention of facilitating easy and efficient feeding on small and medium-sized pet birds that are automatically operated [12].

2. Material and method

2.1. RTC (Real Time Clock) DS1307

Real Time Clock (RTC) as a time limit for a variety of specific applications, widely and commonly used in various electronic equipment [13]. RTC (Real time clock) is an electronic clock in the form of a low-power, full binary (BCD) chip plus 56 bytes NV SRAM. Addresses and data are transferred serially through two-way, two-way buses and can accurately calculate the time (second hour day of the year). And keep/save the time data in real time. Because the clock works in real time, then after the time count process the data output is carried out directly stored or sent to another device through the interface system [14-16]. The DS1307 RTC circuit used is shown in figure 1.

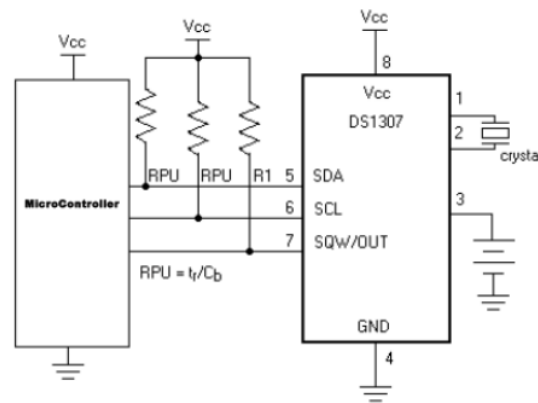

Figure 1. Typical operating circuit RTC DS1307.

2. SIM800L

SIM 800L is a quad band GSM / GPRS module that works on Quad Band frequencies (850/950/1800/1900 MHz) connected to an Arduino and AVR. The GPRS SIM800L feature has multi-slot 12 / class 10 and GPRS CS-1, CS-2, CS-3, and CS-4 coding schemes. The SIM800L module must use a stable voltage of 3.7VDC and the lowest current is 0.7milliamperes so it requires a DC step down converter to reduce the 5VDC voltage from the microcontroller to the SIM800L. SIM800L can be used for all needs in user applications such as smart phones, PDAs, and other mobile devices [17]. The complete SIM800L component diagram block is shown in figure 2.

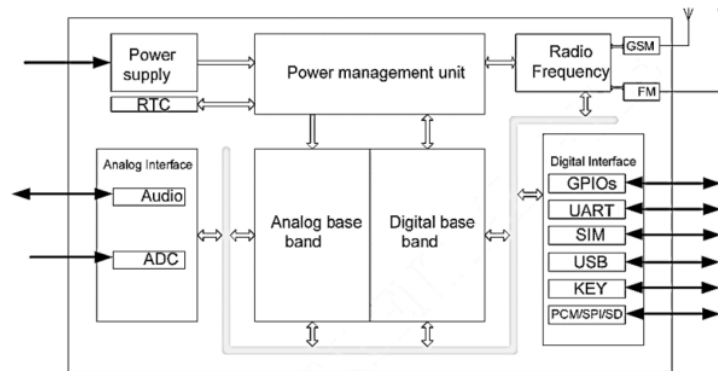

Figure 2. SIM800L function diagram.

2.3. Bird feed scheduling design

This study uses RTC DS1307 for scheduling bird feed and SIM800L as an SMS gateway. RTC DS1307 as an information provider in carrying out servo motor valve opening and closing for bird feeding arrangements. SIM800L as a detector and provides notifications about giving quail feed that has been done. If the clock on the RTC DS1307 has not been set, the system has not yet worked to provide an SMS notification to the bird owner via SIM800L. RTC DS1307 is used to close the feed valve book that is connected to a servo motor at an angle of 0°-90° with a delay of 50 seconds. The feed load tested to move the servo motor is 1 kg to 3 kg. The block of SMS Based Bird Feed Scheduling Diagram is shown in figure 3.

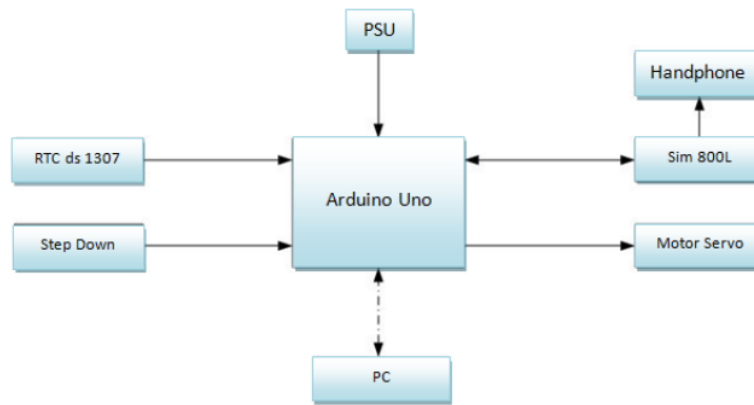

Figure 3. SMS based bird feed scheduling block diagram.

3. Measurement of results

SIM800L in the test produces a voltage of 3.9 volts, because of the step down voltage reduction so that the SIM voltage is stable. Arduino voltage is 5 volts and SIM directly is not connected because no signal is obtained. The measurement of GSM shield voltage is carried out from 1.7 volts to 9 volts, as shown in table 1.

Table 1. Large SIM Voltage (Volt).

No Large Voltage (Volt)		Trial					Average	Standard Deviation
		1	2	3	4	5		
1	1,7	0	0	0	0	0	0	
2	2,5	0	0	1	0	1	0,548	
3	3,9	1	1	1	1	1	0	
4	5	1	0	0	1	1	0,548	
5	9	0	1	0	0	1	0,548	

From the calculation of the standard deviation of the large SIM voltage is 0.548, while the value of 0 (Zero) states that there is no signal. Testing the overall tool for scheduling bird feed automation is adjusted to the size and shape needed. As shown in figure 4.

Figure 4 describes testing of bird feed with a weight of 1 kg to 3 kg. The load test results for opening and closing the bird feed valve using a servo motor with a servo turning angle between 150 to 950. Testing of servo motor weight and angles is shown in table 2 and table 3.



Figure 4. Block text-based bird feed scheduling diagram.

Table 2. Feeder weight (kg).

No	Servo Load	Trial					Average	Standard Deviation
		1	2	3	4	5		
1	1kg	1	1	1	1	1	0	
2	2kg	1	1	1	1	1	0	
3	3kg	1	1	1	1	1	0	

Based on the results of the calculation of the weight standard deviations of the bird feed on the valve opening and opening, it indicates that the tool is running well.

Table 3. Angle of servo motor turning.

No	Servo Angle Round	Trial					Average	Standard Deviation
		1	2	3	4	5		
1	15°	1	1	1	1	1	0	
2	25°	1	1	1	1	1	0	
3	35°	1	1	1	1	1	0	
4	45°	1	1	1	1	1	0	
5	95°	1	1	1	1	1	0	

Based on the results of the calculation of the standard deviation of the servo motor rotational angle of the opening and closing of the bird feed valve shows that the tool is running well.

Testing of SMS based on the provider used is shown in table 4. The test results state that the condition of the provider signal is affected by location and bad weather during testing. So that there are delays or failures of notifications that are sent as information on the scheduling bird feed.

Table 4. Testing of SMS based on the provider.

No	Provider Used	Trial					Average	Standard Deviation
		1	2	3	4	5		
1	SIMPATI	1	1	1	1	1	1	0
2	XL	1	0	0	1	1	0,6	0,548
3	AXIS	1	0	1	0	0	0,4	0,548

4. Conclusion

In the research of SMS-based bird feed automation, scheduling after testing as a whole it can be concluded that the servo motor rotation depends on the weight of the bird feed load accommodated in the container. From a bird feed load of 1 kg to 3 kg with a servo motor turning angle from 150 to 950 it can run well. SMS notification of the three providers, the SEMPATI provider runs well because of the location of the provider to the place where the signal is strong.

Acknowledgments

The author recites University Muhammadiyah Sidoarjo for material and motivational assistance in the participation of conference activities.

References

- [1] Akhmad H S N, Edhy S, Heni S P 2014 Effect of Lighting Duration and Light Intensity on Feed Consumption, Weight gain and Feed Conversion in Japanese Quails *Coturnix Coturnix Japonica* 2014
- [2] Ezugwu A E 2019 Enhanced Symbiotic Organisms Search Algorithm for Unrelated Parallel Machines Manufacturing Scheduling with Setup Times *Elsevier, Knowledge-Based Systems* **172** 15–32
- [3] Giva A M, Gita I H and Dimas J K 2015 Prototype of Control and Automation of Paddy Fields *American Scientific Publishers Advanced Science*
- [4] Vaculik P and Smejtková A 2019 Assessment of selected parameters of automatic and conventional equipment used in cattle feeding *Agronomy Research* **17** (X)
- [5] Olalekan O B 2017 Development of a SIM800L Based Reprogrammable Household Smart Security System with Recipient Phone Call Alert *International Journal of Computer Engineering In Research Trends* **4**(1) 15-20
- [6] Mayda W K, Aswadul F S R and Ahmad D P P 2018 Automation of Bird Feeding and Drinking Sites based on Arduino Board Microcontrollers and GSM 900
- [7] Gheschik S R, Akhmad H and Paulus S W 2011 Feeding Automation System and Egg Laying in a Quail Cage Surabaya, 2011.
- [8] Syahrerini S and Ahfas A 2018 SMS-Based Dust Measurement And Model Analysis Applications *ELINVO (Electronics, Informatics, and Vocational Education)* **3**(1) 18-24
- [9] Muhajirin M and Hadidjaja D 2018 Automation of Feeders and Drinking on Lovebird Bird Cages Based on Arduino UNO and Android
- [10] Aji R, Agus T and Emir N 2013 Designing an Automatic Chicken Feeder System Model Based on Fuzzy Logic Control *ELECTRICIAN – Jurnal Rekayasa dan Teknologi Elektro* **7**(3)
- [11] Mohammad S R, Raihana Z and Ohidujjaman 2018 Advanced Design of Smart Digital Application Using PIC 16F887A Microcontroller and DS 1307 RTC *American Journal of Embedded Systems and Applications* **6**(1) 30-36
- [12] Navaneeth B S and A K Murty Automatic Poultry Feeder 2015 International Journal of Advance Engineering and Research Development, *IJAERD- Scientific Journal of Impact Factor(SJIF)*:

2(7) 338-343

- [13] Ghatte N, Pereira V, Dattaprasad M and Surwadkar T 2014 Real-Time Clock Implementation Using I2C Protocol Check *International Journal of Advanced Research in Electrical, Electronics and Instrumentation Engineering* **3**(1)
- [14] Semiconductor D 2019 DS1307 64 x 8 Serial Real-Time Clock [Online]. Retrieved from: www.maxim-ic.com
- [15] Muhammad S A, Haripuddin H and Satria G Z 2019 Microcontroller Implementation for Automatic Smart Bell *International Journal Of Environment, Engineering and Education* **1**(1) 34-39
- [16] Navaneeth B S and Murty A K 2015 Automatic Poultry Feeder *International Journal of Advance Engineering and Research Development, IJAERD Scientific Journal of Impact Factor(SJIF)* **2**(7) 338-343
- [17] SIMCOM SIM800L Hardware Design V1.00, Shanghai SIMCom Wireless Solutions Co.,Ltd.

IOP Publishing

ORIGINALITY REPORT

12%

SIMILARITY INDEX

11%

INTERNET SOURCES

9%

PUBLICATIONS

%

STUDENT PAPERS

PRIMARY SOURCES

1	repository.unhas.ac.id Internet Source	3%
2	Sameer Pokhrel, Sameh A Eisa. "A novel hypothesis for how albatrosses optimize their flight physics in real-time: an extremum seeking model and control for dynamic soaring", <i>Bioinspiration & Biomimetics</i> , 2022 Publication	1%
3	www.physics1.howard.edu Internet Source	1%
4	d.docksci.com Internet Source	1%
5	upcommons.upc.edu Internet Source	1%
6	www.repo.uni-hannover.de Internet Source	1%
7	Victor Colognesi, Renaud Ronsse, Philippe Chatelain. "Model coupling biomechanics and fluid dynamics for the simulation of controlled	1%

flapping flight", Bioinspiration & Biomimetics, 2021

Publication

8	mdpi-res.com Internet Source	1 %
9	www.irjet.net Internet Source	1 %
10	manualzz.com Internet Source	1 %
11	cpr.undip.ac.id Internet Source	<1 %

Exclude quotes Off

Exclude matches Off

Exclude bibliography On