

Integral Education

by Hidayatulloh Hidayatulloh

Submission date: 17-Apr-2023 02:12PM (UTC+0700)

Submission ID: 2066987329

File name: 2022_pros_inter_Integral_Education.pdf (319.71K)

Word count: 2551

Character count: 14034

Research article

Integral Education Based on Tauhid for Forming Kamil People

Kamad Kamad and Hidayatulloh Hidayatulloh*

Management of Islamic Education, University of Muhammadiyah Sidoarjo

ORCIDHidayatulloh Hidayatulloh: <https://orcid.org/0000-0002-3121-0890>**Abstract.**

The fundamental premise of both the Indonesian national and Islamic education systems is to form intelligent, faithful, and pious human beings or students. This study aimed to analyze the concept of monotheism-based integral education that can lead students, teachers, and school members to recognize, understand, practice, and enjoy Islam as a real view of life. This study was a literature review of previous research articles published between 2017 and 2021 and available from the lens.org. The results indicated that monotheism-based integral education is a conscious, structured and systematic effort to succeed in the mission of human creation based on the guidance of revelation and that this monotheism-based integral education can successfully produce *kamil* people.

Keywords: integral education, based on *Tauhid*

Corresponding Author:
Hidayatulloh Hidayatulloh; email:
hidayatullah@umsida.ac.id

Published 20 June 2022

Publishing services provided by
Knowledge E

© Kamad Kamad and
Hidayatulloh Hidayatulloh. This
article is distributed under the
terms of the [Creative Commons
Attribution License](#), which
permits unrestricted use and
redistribution provided that the
original author and source are
credited.

Selection and Peer-review under
the responsibility of the ICIGR
2021 Conference Committee.

1. Introduction

Education is one of the most important factors in shaping human beings to be better, of quality, and of character. [1] Education is an integral part of the development of the life of the nation and state, as stated in the Law on the National Education System Number 20 of 2003 article 1, which reads: "Education is a conscious and planned effort to create a learning atmosphere and learning process so that students actively develop their potential to have religious spiritual strength, self-control, personality, intelligence, noble character, and skills needed by themselves, society, nation and state.

In order to produce students with the characteristics as stated in Article 1 of Law Number 20 of 2003 above, it is necessary to integrate three transfers in the education and learning process, namely transfer of knowledge, transfer of competence, and transfer of values. For this reason, a new down-to-earth education strategy is needed, and in the implementation of Islamic education reform, an educational model is needed that is able to accompany the goals and objectives of Islamic education. When Islamic

OPEN ACCESS

education is used as a paradigm, the entire education must also adapt from Islamic teachings.[2]

This study uses a Systematic Literature Review (SLR) which explores a monotheistic-based integral education model. And the focus of the discussion of this research is how integral education is based on monotheism in shaping human beings.

Several questions to be answered in the literature research in this article are formulated as follows: (1) What is meant by monotheism-based integral education?; and (2) How is integral education based on monotheism in shaping human beings?

2. Research Methodology

The research method used in this study is the Systematic Literature Review (SLR) approach. In SLR research, it starts from identifying, analyzing, evaluating, and interpreting all relevant research results related to certain research questions, certain topics, or phenomena of concern. The object of the literature review in this research is related to monotheism-based integral education in forming human beings.

The method in this study uses a literature study using relevant previous research articles on the lens.org website. The search for articles in this study took a time span from 2017 to 2021 and collected as many as 23 reference sources according to the problems studied. The stages of searching for articles in this study are systematically presented with the following scheme;

Stage 1 : In the initial search for references adjusted for the title variable, namely "Education+integral+based+tawhid", a database of 244 articles was found..

Stage 2 : After looking at the first stage of the search, many articles were found that did not match, the researchers extended the search and filtered the articles using a range of years for the last 5 years using the same keywords, and the results were 156 articles.

Stage 3 : From the results of the second stage, the researcher made an abstract mapping and conclusion to make it easier for researchers to analyze.

Stage 4 : At this stage the researcher records the relevant literature according to the keywords in the search. Then the researcher retains from the search results and includes the appropriate literature.

Stage 5 : From all 23 articles, they were recorded and analyzed in a structured and systematic way, then read through a screening process, eliminating all articles that were not appropriate, and finally 9 articles were selected to be analyzed.

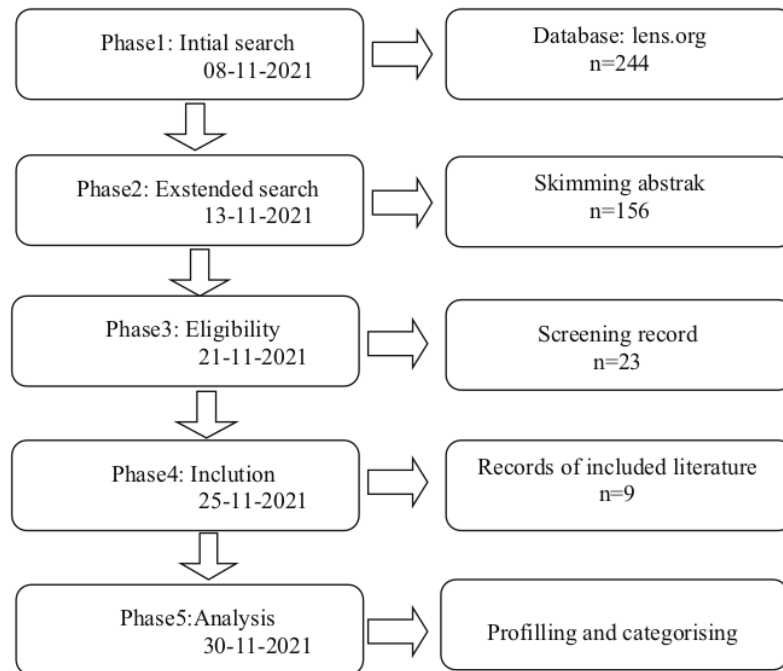

Figure 1: Systematic Review Prism.

3. Finding

As mentioned above, only 9 articles were retained and relevant enough to be researched and analyzed intensively. Then this study is classified into groups based on three main things, namely: (1) the place of research (2) the strategy, and (3) the methodology used, which can be explained as follows:

1) Research site

This study focuses on research articles taken from lens.org where researchers collect several articles that do not focus on just one article, but many articles with the keywords of integral education based on monotheism.[3]

2) Research strategy

The researcher used the initial strategy, namely mapping from various kinds of literature taken from lens.org which was adjusted with keywords. From some of these articles, 9 articles were obtained that were relevant to research which were adapted to the researcher's keywords. [4]

3) Research methodology

This article was compiled using the Systematic Literature Review (SLR) method taken from full lens.org. This SLR method is used to identify, evaluate and interpret all the research that has been mapped. Researchers review and identify articles in a structured manner and follow a predetermined template. The keywords used are "Education + integral + based + monotheism". The articles taken are articles with a time span of 2017-2021. Furthermore, the researcher categorizes the articles of monotheism-based integral education. [3]

4. Research Focus

The researcher focuses on two main things, namely integral education based on monotheism and the formation of human beings taken from 9 selected articles as the sources analyzed. For these two main things, the following stages are carried out:

1. (a) Explore the terms education+integral+based+tawhid from 9 selected articles.
(b) Researching 9 selected articles that are considered relevant to integral education or meaningful, either directly or indirectly, which states that integral education based on monotheism is able to shape human beings.

5. Article Category

To introduce the features of monotheism-based integral education from 9 selected articles as a reference source and made sure that they are relevant. To read the mind maps of 9 articles with the keyword tawhid-based integral education reveals that the results of the implementation of monotheistic-based integral education are able to produce a civilized and accomplished generation so that they become human beings. [5]

6. Discussion

Education is a conscious human effort in order to form and realize a complete human person.[2] Integral or integration is merging or blending so that it becomes a unified whole.[6] Thus, integral education can be interpreted as a conscious effort in order to form and realize a complete human person by combining all existing potential.

Tawhid is part of a Muslim's aqidah to Allah Almighty. Tawhid is a very important and basic matter, because monotheism is the core of Islamic teachings. If a person's

monotheism is right, then his Islam is good, and if his monotheism is broken, then his deeds are in vain.[7] Based on monotheism, it means to link all activities to the oneness of Allah.

So, integral education based on monotheism is a conscious effort in order to form and realize a complete human person by combining all existing potential and linking all activities to the oneness of Allah ta'ala.

As an activity that is engaged in the process of fostering the human personality, integral education based on monotheism requires a principle or basis on which to work [8].

The implementation of monotheistic-based integral education refers to the tarbiyah divineyyah process, namely the method used by God in educating his apostles in guiding his people, namely through the process of recitation, tazkiyah and taklimah as stated in the QS. Al Jumu'ah: 2. [5]. These three things are explained as follows:

First, recitation, which is guiding students to know Allah through His verses that are in the Qur'an, the universe, and themselves, after understanding themselves and the creation of the universe they are guided to feel the presence of Allah in all activities. his life.[5]

The fruit of the journey of the recitation phase is the birth of a conscious statement as an acknowledgment "that there is no god but Allah" or known as the creed of monotheism (lailaha illallah).

Second, tazkiyah, namely purification or at tazkiyah which comes from the word zaka-a-yazku-zaka-a-an which means holy. At-tazkiyah means growing, holy and blessed. Ibn Taimiyah explained that at-tazkiyah is making something holy, both in substance, belief and physicality. In its basic sense this word means to grow, develop, clean. This means, by knowing Allah students will be purified from things that can damage and at the same time develop the potential for goodness and they will become civilized human beings.[5]

In this tazkiyah method, it is marked by the hard work of removing and eroding five kinds of barriers to the functioning and role of the creed, namely thagho (arrogance), hubbud dunya (love of the world), being controlled by lust, fond of sinning and lacking in mujahadah and riyadhoh (sincerity and practice). [5]

Third, ta'limah, namely the process of providing knowledge, understanding, responsibility, and instilling trust. Muhammad Rasyid Rida provides a definition of ta'lim as the process of transmitting various knowledges to the individual soul without certain limitations and conditions.[5]

In its implementation, the monotheism-based education curriculum is applied in all subjects, both general subjects and religious subjects. All teachers must be able to explain to the children every theme of the subject matter being taught to introduce Allah taala.

Insan Kamil is a perfect human in terms of form and knowledge. It is called perfect in terms of its form because the human being is a perfect manifestation of the image of God, which is reflected in the names and attributes of God as a whole. As for being perfect in terms of knowledge, it means having reached the highest level of consciousness, namely realizing the existence of one's god, which is called ma'rifat. The result of implementing this monotheistic-based integral education is to give birth to a civilized and accomplished generation so that they become human beings. [5]

From the discussion above, it is illustrated that monotheism-based integral education can form insal kamil which is diagrammatically illustrated below.

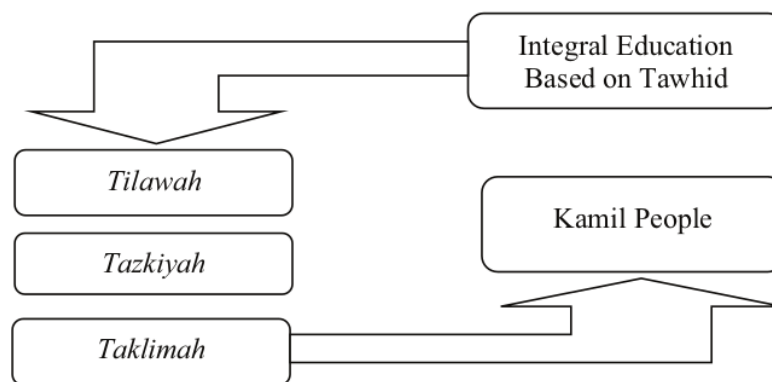

Figure 2: Integral Education Based on Tawhid.

7. Research Questions and Answers

1) The first question: What is meant by monotheism-based integral education?

Answer: Integral education based on monotheism is a conscious effort in order to form and realize a complete human person by combining all existing potential and linking all activities to the oneness of Allah ta'ala.

2) The second question: How is integral education based on monotheism in forming human beings?

Answer: Refers to the tarbiyah divineyyah process, namely the method used by God in educating his apostles in guiding his people, namely through the process of recitation,

tazkiyah, and taklimah as stated in the QS. Al-Jumu'ah: 2. Then in the implementation of the monotheism-based education curriculum, it is applied in all subjects, both general lessons and religious lessons. All teachers must be able to explain to students every theme of the subject matter being taught to introduce God Almighty, so that the results of the implementation of this monotheistic-based integral education are able to give birth to a civilized and accomplished generation, so that they become human beings.[5]

8. Reflection

After researching 9 relevant articles, it can be reviewed that integral education based on monotheism is very relevant in the world of education. Given from several literatures and studies focusing on education itself.

The results of this study indicate that monotheism-based integral education is a conscious, structured, and systematic effort to succeed in the purpose of human creation based on revelation guidance, and the results of monotheism-based integral education are able to form human beings.[9] Therefore, the results of this study are very important to become new ideas, ideas, and theories in improving conventional education and learning, which are able to produce human beings.

9. Conclusion

- 1) Integral education based on monotheism is a conscious effort in the context of forming and realizing a complete human person by combining all existing potential and linking all activities to the oneness of Allah ta'ala.
- 2) The implementation of monotheism-based integral education is able to give birth to a civilized and accomplished generation, so that they become human beings.[5]
3. Integral education based on monotheism is able to form human beings.[9]

References

- [1] Fathul Amin, "Pembentukan Karakter Melalui Pendidikan Agama Islam," *Tadris*, vol. 12, no. 2, hlm. 33–45, Nov 2019, doi: 10.51675/jt.v12i2.22.
- [2] B. Bashori, "Paradigma Baru Pendidikan Islam (Konsep Pendidikan Hadhari)," *JuPe*, vol. 11, no. 1, hlm. 141–174, Feb 2017, doi: 10.21043/jupe.v11i1.2031.

- [3] H. Djainudin dan S. Sirait, "Pembelajaran Tauhid Berbasis Lingkungan Di Smp It Alam Nurul Islam Yogyakarta," *PAI.J.PEND.ISLAM.*, vol. 13, no. 1, hlm. 117–131, Apr 2017, doi: 10.14421/jpai.2016.131-08.
- [4] M. Ulum, "Pembentukan Karakter Siswa Melalui Pendidikan Berbasis Pondok Pesantren," *evaluasi*, vol. 2, no. 2, hlm. 382–397, Sep 2018, doi: 10.32478/evaluasi.v2i2.161.
- [5] K. Umam, "Implementasi Kurikulum Berbasis Tauhid di SD Integral Yaa Bunayya Plosoarang Kecamatan Sanankulon Blitar," *intelektual*, vol. 7, no. 1, hlm. 54–62, Mei 2017, doi: 10.33367/intelektual.v7i1.369.
- [6] R. Rusdiyanto, "Integrasi Pendidikan Dan Implikasinya Terhadap Lembaga Pendidikan Di Indonesia," *TA'LIMUNA*, vol. 7, no. 1, hlm. 13, Agu 2018, doi: 10.32478/ta.v7i1.145.
- [7] T. W. Ramdhan, "Desain Kurikulum Pendidikan Islam Berbasis Tauhid," *alinsyiroh*, vol. 5, no. 1, hlm. 118–134, Mar 2019, doi: 10.35309/alinsyiroh.v5i1.3400.
- [8] M. Khoiruddin, "Pendidikan Sosial Berbasis Tauhid dalam perspektif Al-Qur'an," *Tarbawi*, vol. 3, no. 1, hlm. 73–82, Jun 2018, doi: 10.22515/attarbawi.v3i1.1141.
- [9] A. Abdurrahman, "Implementasi Manajemen Kurikulum Pesantren Berbasis Pendidikan Karakter," *at-turas*, vol. 4, no. 2, hlm. 279–297, Sep 2018, doi: 10.33650/at-turas.v4i2.336.

Integral Education

ORIGINALITY REPORT

14%

SIMILARITY INDEX

11%

INTERNET SOURCES

9%

PUBLICATIONS

%

STUDENT PAPERS

MATCH ALL SOURCES (ONLY SELECTED SOURCE PRINTED)

3%

★ Suhirman Suhirman, Muhammad Abdu, Sirajudin Sirajudin, Azwar Rahmat. "Evaluation Of Total Quality Management In The Achievement Of Quality Of Ma'had Al-Jami'ah IAIN Curup In The Middle Of The Covid-19 Pandemic", International Journal of Educational Review, 2022

Publication

Exclude quotes Off

Exclude matches Off

Exclude bibliography Off