



TERAKREDITASI INSTITUSI B
SK NO. 229/BAN-
PT/AKRED/PT/IV/2015

UNIVERSITAS MUHAMMADIYAH SIDOARJO

DIREKTORAT RISET DAN PENGABDIAN MASYARAKAT

Alamat: Jl. Mojopahit 666 B Sidoarjo 61215, Telp. 031-8945444 psw.130, Faks. 031-8949333 Email:
lppm@umsida.ac.id, Website: lppm.umsida.ac.id

Surat Keterangan Tidak Plagiat [Kepangkatan]

Nomor: 776.2/II.3.AU/14.00/C/KET/I/2023

Kepada Yth :
Bpk. Izza Anshory, ST., MT., Dr.
Di

Tempat

Assalamua'alaikum Wr. Wb.

Sehubungan dengan adanya permohonan Surat Keterangan Tidak Plagiat dengan rincian:

Judul Artikel : Monitoring and Optimization of Speed Settings for Brushless Direct Current (BLDC) Using Particle Swarm Optimization (PSO)

Nama Pemohon : Izza Anshory / TEKNIK ELEKTRO

URL Sinta Pemohon : <https://sinta.kemdikbud.go.id/authors/profile/5993144>

Nama Penulis : Izza Anshory

Tujuan : Kepangkatan

Tujuan Kepangkatan : Lektor

Naskah Yang Dimohonkan pengecekan:

<https://dosen.umsida.ac.id/modul/publikasi/filesktp/202239/sktp-10-01-2023%2002:35:03-202239.pdf>

Artikel tersebut DAPAT digunakan untuk proses kepangkatan.

Demikian surat keterangan ini kami sampaikan, mohon untuk digunakan sebagaimana mestinya.

Wassalamu'alaikum Wr. Wb.

Mengetahui,
Wakil Rektor 1
Universitas Muhammadiyah Sidoarjo

Hana Catur Wahyuni, ST., MT

Direktur DRPM

Universitas Muhammadiyah Sidoarjo

Dr. Sigit Hermawan, S.E., M.Si

sktp-10-01-2023 02_35_03- 202239

by Izza Anshory, St., Mt., Dr.

Submission date: 11-Jan-2023 08:59AM (UTC+0700)

Submission ID: 1991009508

File name: sktp-10-01-2023_02_35_03-202239.pdf (476K)

Word count: 3399

Character count: 16536

Monitoring and Optimization of Speed Settings for Brushless Direct Current (BLDC) Using Particle Swarm Optimization (PSO)

Izza Anshory^{1,2}

¹Department of Electrical Engineering
Institut Teknologi Sepuluh Nopember (ITS)
Surabaya 60111, Indonesia

²Department of Electrical Engineering
Universitas Muhammadiyah Sidoarjo
Sidoarjo, 601271

izza.anshory15@mhs.ee.its.ac.id

Imam Robandi¹

¹Department of Electrical Engineering
Institut Teknologi Sepuluh Nopember (ITS)
Surabaya 60111, Indonesia

robandi@ee.its.ac.id

Wirawan¹

¹Department of Electrical Engineering
Institut Teknologi Sepuluh Nopember (ITS)
Surabaya 60111, Indonesia

wirawan@ee.its.ac.id

Abstract- This paper presents the setting of the speed of a motor Brushless Direct Current (BLDC) optimized by artificial intelligence. It discusses the comparison between the speed setting of BLDC motor optimized by Particle Swarm Optimization (PSO) and with optimization. The finding shows that the performance of the BLDC motor speed setting optimized by PSO algorithm provides optimal value for the proportional gain constant of 27.0384, integral gain of 5.1108, integral derivatives of 1.9394 and smaller errors of 2.835. In short, the use of PSO algorithm can speed up the stability and reduce the errors.

Keywords: PID; BLDC motor; PSO algorithm; optimization

I. Introduction

Brushless Direct Current (BLDC) motors have been widely used for industrial automation equipment and electric cars, which requires checks on the performance of the motor condition continuously. The performance electric motor can be maintained by checking changes in electrical current and voltage signal input by placing a sensor on the motor. Research on monitoring changes in input voltage and current signals to the electric motors have been done using Fourier transform analysis methods such as Hilbert-Huang Transform [1].

Data from the monitoring of changes in input voltage and electrical current is used as a basis for determining a change of pace in the BLDC motor. Control of the speed change can be done by optimizing the values of *Proportional Integral Derivative* (PID) controller parameters to get the best response by artificial intelligence algorithms. In the past years, many researchers have used artificial intelligence algorithms (bee colony [2], harmony search [3], genetic algorithm and simulated annealing [4], etc.), and PSO-based PID Tuning Tool to get overshoot ratio, the rising time, the settling time [5].

In this paper, we propose a monitoring signal changes in current, voltage, and speed of the BLDC motor power of 350 watts, to directly measure and compare their results in terms of stability and errors generated when using PID controller and PID-tuned with PSO algorithm. The BLDC motor

transfer function model used is the motor model Segway of Haris Khan [6].

II. THEORETICAL BACKGROUND

A. Mathematical Model of BLDC Motor

BLDC motor is a synchronous machine that is used to convert electrical energy into mechanical energy generated by the magnetic field of the stator and rotor. Based on the existing rotor position, then the required speed controllers is appropriate to achieve the desired engine performance. A BLDC motors generally have three windings are connected in star mode. Each winding coil is formed by a large number of interconnected, with two different types of stator windings which is kind of trapezium and sinusoidal.

This difference is formed on the basis of the relationship of the coils in the stator windings to produce many types of back *electromotive force* (EMF). BLDC motor system the overall consists of three parts: (i) the PWM inverter power conversion, (ii) the BLDC motor and load, and (iii) speed, torque, and current controller. PWM inverter drives the four pole permanent magnet on the rotor magnet three-phase motor. Three hall sensor installed on the stator will detect the order of the switching transistor *insulated gate bipolar transistor* (IGBT) to the rotor position. The equation of motion, the torque equation and the voltage equation is an equation on model BLDC motor [7].

The circuit diagram for the stator winding is as shown in Figure.1.

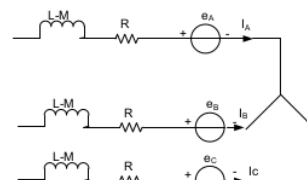

Figure 1. Circuit diagram stator winding

The voltage equations at the different terminals are as shown below [8]:

$$V_a = I_a R + L \frac{di_a}{dt} + E_a \quad (1)$$

$$V_b = I_b R + L \frac{di_b}{dt} + E_b \quad (2)$$

$$V_c = I_c R + L \frac{di_c}{dt} + E_c \quad (3)$$

Where, $L_a=L_b=L_c = L$: self-inductance [H]
 $R_a=R_b=R_c = R$: phase resistance [Ω]
 $V_a=V_b=V_c= V$: phase voltages [V]
 $I_a= I_b = I_c = I$: phase current[A]
 $E_a= E_b =E_c = E$: back EMF [V]

The EMF voltages are functions of the rotor mechanical speed ω_m and the rotor electrical angle θ_r is [7]

$$E_a = k_a \omega_m \quad (4)$$

$$E_b = k_b \omega_m \quad (5)$$

$$E_c = k_c \omega_m \quad (6)$$

The coefficients k_a , k_b , and k_c are dependent on the rotor angle θ_r . The transfer function BLDC Motor is [9],

$$G(s) = \frac{\omega_m}{V_s} = \frac{\frac{1}{K_e}}{\tau_m \tau_e s^2 + \tau_m s + 1} \quad (7)$$

Where ω_m = angular velocity,
 V_s = source voltage,
 K_e = the back emf constant,
 τ_m = the mechanical (Time constant),
 τ_e = the electrical (Time constant),

In this experiment refers to mathematical model BLDC Motor Segway from Harris Khan [6]

$$G(s) = \frac{\omega(s)}{V(s)} = \frac{3.2788}{s + 0.8767} \quad (8)$$

B. Proportional Integral Derivative (PID)

Applications in the modern industrial world today, has been widely implement PID control system for process improvement and control of motion. The control system becomes unstable and performing poorly if we are not precise in determining the values of PID controller tuning constants. Settling time, overshoot, and steady-state error determines the desired performance criteria through the parameter values K_p , K_i and K_d . In this paper we propose a PSO algorithm to find the optimal value of the parameter values K_p , K_i and K_d for BLDC motor speed control system [10].

Parameter proportional (P), integral (I) and derivative (D) controller applied to the diagram in figure 2 [11]:

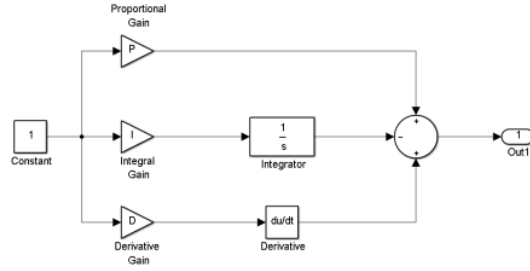

Figure 2. Simulation model of PID Controller

The transfer function of PID controller is

$$C(s) = K_p + \frac{K_i}{s} + K_D s \quad (9)$$

Where K_p = Proportional gain,
 K_i = Integral gain
 K_d = Derivative gain.

The equation PID controller is described as follows:

$$u(t) = K_p e(t) + K_i \int_0^t e(t) dt + K_d \frac{d_e}{dt} \quad (10)$$

Where u_i is the controller output, t is the sampling instance, e_i is the error.

C. PSO Algorithm

PSO is one method of optimization based on herd behavior of bees. Each bee in the crowd will be looking for areas that have a significant amount of food the most. Each individual bee locate food will forward the information to the entire crowd of bees, and then compare each new location has been found with other locations that have higher density.

Before obtaining location information has a higher density of the food, then the bees will keep the location has been found. Each bee has been informed about the best location, and adjust the position and speed of each end, the whole crowd will collectively gather at the location with the highest density of the food. Any individual or particles behave in a distributed manner by using its own intelligence and is also influenced by the behavior of the collective group[12].

The PSO algorithm iterative procedure follows the following equation [5]:

$$V_{ij}^{(k+1)} = w x v_{ij}^{(k)} + c_1 x rand() x (pbest_{ij} - x_{ij}^{(k)}) + c_2 x rand() x (gbest_j - x_{ij}^{(k)}) \quad (10)$$

$$x_{ij}^{(k+1)} = x_{ij}^{(k)} + v_{ij}^{(k+1)} \quad (11)$$

Where:

v_i : Current velocity of agent i at iteration.

j : The PID parameter specie number

k : an iteration number

v : a moving vector

$pbest$: a personal best of particle i

$gbest$: a global best of all particles

$w, c1$ and $c2$: weight parameters

$rand()$: a uniform random number 0 to 1

ω : weight function for the velocity of agent i ,

$c1, c2$: positive constants; [$c1 + c2 < 4$].

In this paper we propose a number of particles to obtain the optimal exploration is 20, the number of iterations of each particle is given to obtain optimum PID values to be successful is 50 and the value social factors of C_1 are set to 1 and C_2 is set to 2.

III. DESIGN OF MONITORING OF SPEED SETTING FOR BLDC MOTOR BASED ON PSO ALGORITHM

The block diagram for Monitoring and optimization of speed setting for BLDC Motor using PSO can be explained as follows:

A. The Monitoring Systems BLDC Motor with Interface Microcontroller to computer;

In this system, the BLDC motor parameter such as current, voltage, and speed rating are monitored and controlled. At the BLDC Motor side speed, voltages, current are continuously monitored by the appropriate sensors. The speed sensor is used to monitor the speed rotate per minute (rpm) of the motor is as shown in Figure.3.

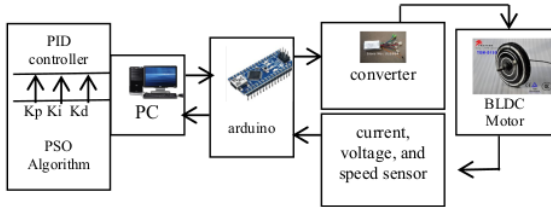

Figure 3. Block Diagram Monitoring and Optimization of Setting Speed BLDC Motor using PSO.

The sensed signals current, voltage, and speed sensor is input to the microcontroller arduino. The microcontroller will decode and analyze it. The various sensor inputs will transmit the signal to a Personal Computer. The data will be displayed on a PC through microcontroller arduino. PC will monitor current, voltage, and speed data of all sensors with date and time.

B. Optimization setting BLDC motor based on the PSO - PID Controller.

Figure 4 shows the block diagram transfer function BLDC motor and the response of the open loop system of the motor respectively.



Figure 4. Block Diagram of the Open Loop System

Designing the PID controller mainly means obtaining the three parameters, so how to configure the three parameters of PID (K_p, K_i, K_d) is important for the performance of the whole control system. In this paper, the PSO algorithm is proposed to search the optimal parameters.

The implementation steps of parameter optimization of PID controller based on PSO can explain as follows:

1. Step 1: generate the initial number of population size is set to 20.
2. Step 2: to determine the fitness value of each particle.
3. Step 3: Initialize the range of particles in order to accelerate the calculation speed.
4. Step 4: to determine the fitness value, calculate the fitness value of each particle.
5. Step 5: If the maximum iteration number comes to the end of the performance criteria is satisfactory, the system gets the optimal solution.

In the control system of BLDC motor, the controlled value of the controller is the speed of the BLDC motor and the voltage is the output. The difference of reference input and measuring speed is the input of the controller; finally, the motor speed is steady. Structure diagram of the PID control system is shown in Figure 5.

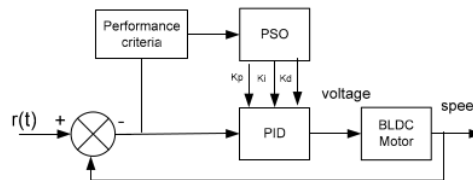

Figure 5. Structure diagram of PID controller system

This controller is designed mainly for the following two components: the PID controller for the object and the module of the PSO algorithm. According to the operating state of the system, the module of PSO can optimize the parameters of the PID controller to meet the performance requirements, and the output of this module will provide the optimized parameter of PID controller.

IV. SIMULATION AND RESULT

In order to confirm the advantage of the proposed monitoring and optimization speed setting for BLDC Motor using PSO, several simulations have been conducted via MATLAB SIMULINK. A BLDC motor connected with a sensor to take current, voltage and speed.

A. Monitoring BLDC Motor

Figure 6 shows in the experiments, data sensor voltage, current and speed to transmit Personal Computer (PC) through interface Microcontroller Arduino.

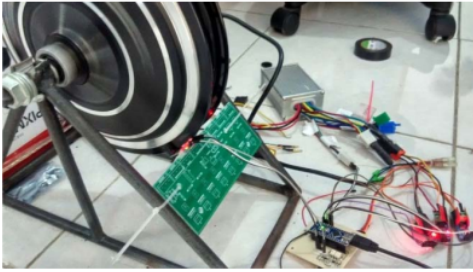

Figure 6. Taking Data Measurement of BLDC Motor

Voltage, current and speed BLDC Motor signals are measured real-time, and the experimental setup is listed in Table I. On the table indicates that there are changes in the voltage and current of each corresponding phase. Changes the voltage and current generating motor speed.

Table 1. Data measurement Voltage, Current, and Speed BLDC

Time	PWM	Current			Voltage			Speed (rpm)
		I ₁	I ₂	I ₃	V ₁	V ₂	V ₃	
1.00	176	0.91	0.15	0.33	40	0	45	0
2.01	177	0.46	0.01	0.57	20	30	0	346
3.02	178	0.01	0.22	1.25	20	30	0	280
4.02	179	0.01	0.49	0.94	45	30	0	276
5.02	180	0.59	0.33	0.91	0	0	0	276
6.03	181	0.81	0.57	0.25	0	45	10	273
7.04	182	0.01	0.12	0.3	0	5	0	280
8.04	183	0.22	0.01	0.54	0	45	20	283
9.05	184	0.67	0.22	0.52	10	0	0	280
10.05	185	0.2	0.89	0.3	45	25	0	283
11.06	186	0.01	0.81	0.44	20	0	15	293
12.08	187	0.81	0.12	0.3	0	0	0	293
13.07	188	0.33	0.59	0.36	45	0	45	300
14.07	189	0.01	0.15	0.01	0	0	0	306
15.08	190	0.41	0.22	1.31	0	0	0	300
16.09	191	0.7	0.3	0.41	5	45	0	306
17.09	192	0.25	0.12	0.49	45	5	0	303
18.09	193	0.15	0.33	0.49	30	0	25	310
19.10	194	0.09	0.67	0.3	45	30	0	316
20.11	195	0.15	0.59	0.36	5	5	45	320
21.11	196	0.54	0.12	0.38	45	15	0	316
22.11	197	0.01	0.33	0.52	35	45	0	316
23.12	198	0.59	0.44	0.46	30	0	20	323
24.13	199	0.67	0.01	0.59	0	30	30	326
25.13	200	0.25	0.78	0.07	0	0	45	330
26.13	201	0.12	0.01	0.01	0	0	45	330
27.14	202	0.54	0.49	0.28	40	0	45	336
28.14	203	0.46	0.54	0.33	25	0	45	336
29.15	204	0.01	0.46	0.01	0	0	45	343
30.15	205	0.83	0.15	1.04	5	0	0	343

Figure 7 illustrates about curve data measurement speed for point time 2 second achieved overshoot.

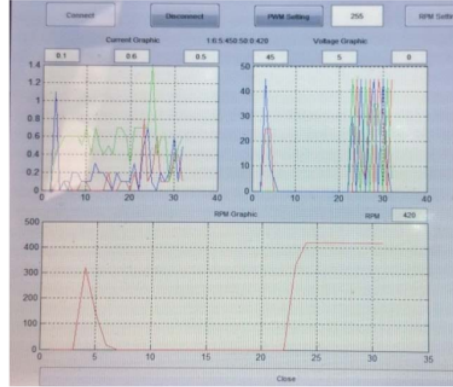

Figure 7. The result monitoring BLDC motor from PC. Figure 7 shows the test chart directly to changes in voltage, current and speed of the BLDC motor. Monitoring results indicate instability and overshoot on the speed of the motor during the test.

B. Open Loop System Monitoring BLDC Motor

Figure 8 illustrates open loop system monitoring BLDC motor, the result shows as follows:

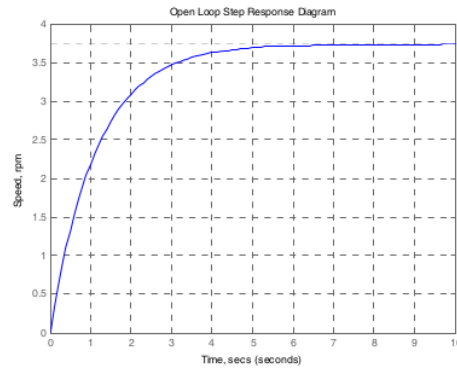

Figure 8. Graphic Open Loop System

Figure 8 explains that in order to achieve stability filled in seconds to 5 with the motor speed to the point to 375 rad / sec.

C. Close Loop System BLDC Motor

In this paper, a simple PID controller is designed and simulated using the methodology shown in Figure 9. In the baseline case, the PID control gains respectively $K_p=0.8$, $K_i=48$, and $K_d=0.01$

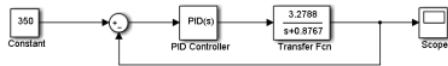

Figure 9. Block diagram with PID

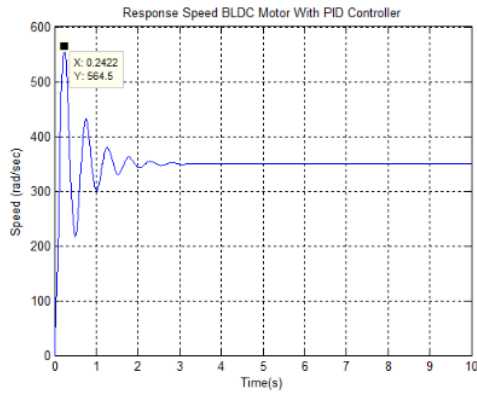

Figure 10. PID simulation result of response Speed BLDC Motor With PID Controller

Figure 10 explained that overshoot value at speed 564 rad/sec and time at 0.242 Sec. This shows the instability at the beginning of the BLDC motor is turned on.

D. Optimization BLDC Motor with PSO Algorithm

In this study, in order to acquire better performance and PID system speed control BLDC motor driver designed for off-line using the PSO algorithm. Tasks performed PSO algorithm is each looking for speed and the best position to achieve optimization purposes.

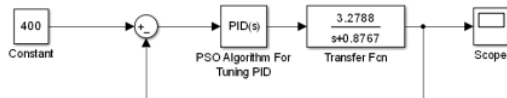

Figure 11. Block Diagram PSO Algorithm for Tuning PID

Figure 11 shows the design of a PID controller using the PSO algorithm for tuning the parameters K_p , K_i , and K_d .

Table 2 shows the PSO parameters that provide the best results.

Table 2. Value of parameters for PSO algorithm

Parameter	PSO
Number of Particles	20
Number of iterations	50
C1(social constant)	1
C2 (Cognitive Constant)	2

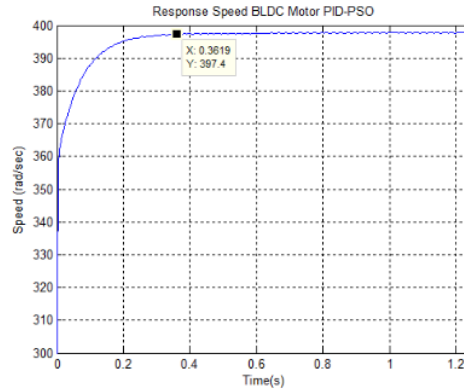

Figure 12. Step response of BLDC Motor in PSO based PID

As shown in Figure 12 shows that the PSO algorithm has a better dynamic response with parameter values $K_p=27.0384$, $K_i = 5.1108$, $K_d = 1.9394$, $g_{best}=2.4157e+06$, value peak overshoot is 397.4 at time steady state is 0.3619.

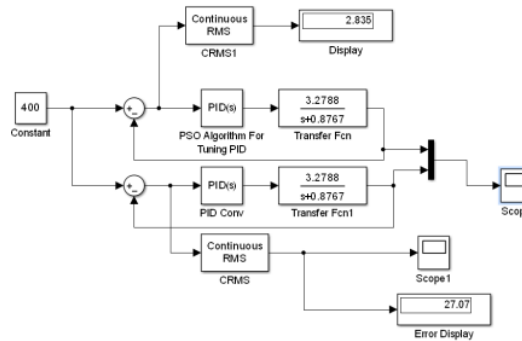

Figure 13. Comparison error, PID and PID Tuning PSO

Figure 13 explain that error value which result from PID tuning with PSO is 2.835 and error value PID without PSO is 27.07. This result that optimization PID controller with PSO algorithm better than PID Controller without PSO algorithm.

E. Comparison Measuring Data, PID, and Optimization PSO

After simulation, optimization PSO for find parameter PID, we can compare measuring data reality with PID, and PSO algorithm.

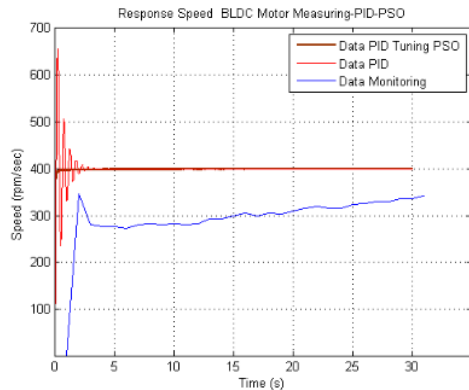

Figure 14. Comparison Response BLDC Motor

Figure 14 explained about comparison response BLDC Motor which measuring from motor, using PID and optimization controller PID using PSO. The result shows that using particle swarms optimization better than measuring reality BLDC motor and PID.

V. CONCLUSIONS

The stability, performance BLDC motor can be controlled through monitoring and optimization algorithm speed setting using Particle Swarm Optimization (PSO). The measurable results in 30 seconds directly to changes in voltage, current and speed of the BLDC motor 350 Watt, shows that when the early start on the second-to-second speed overshoot there is 346 rad / Sec and a lack of speed stability conditions during testing. It is different when the implementation of PID controller and PSO algorithm to optimize the speed setting. The simulation results showed that the speed of the motor speed and stability at 397.4 rad/Sec, at 0.3619 Sec. PSO algorithm implementation to optimization of PID controller generates an error of 2.835, whereas without optimization error generated at 27.07. From this test can be concluded that the use of the PSO algorithm optimization BLDC motor speed setting fewer mistakes than without optimization.

ACKNOWLEDGMENT

This work is part of research electric vehicle and we acknowledge BPPDN for the Domestic PhD Scholarship at Department Electrical Engineering ITS Surabaya.

REFERENCE

- [1] M.-C. Tsai, S.-K. Lin, and S.-H. Wang, "Condition monitoring of BLDC motor drive systems by Hilbert Huang Transform," in *2015 Tenth International Conference on Ecological Vehicles and Renewable Energies (EVER)*, 2015, pp. 1–5.
- [2] W. Liao, Y. Hu, and H. Wang, "Optimization of PID control for DC motor based on artificial bee colony algorithm," in *2014 International Conference on*

Advanced Mechatronic Systems (ICAMEchS), 2014, pp. 23–27.

- [3] A. Rahideh and T. Korakianitis, "Brushless DC motor design using harmony search optimization," in *2011 2nd International Conference on Control, Instrumentation and Automation (ICCIA)*, 2011, pp. 44–50.
- [4] K. S. R. Rao and A. H. Bin Othman, "Design optimization of a BLDC motor by Genetic Algorithm and Simulated Annealing," in *International Conference on Intelligent and Advanced Systems, 2007. ICIAS 2007*, 2007, pp. 854–858.
- [5] A. Oi, C. Nakazawa, T. Matsui, H. Fujiwara, K. Matsumoto, and H. Nishida, "PID optimal tuning method by Particle Swarm Optimization," in *SICE Annual Conference, 2008*, 2008, pp. 3470–3473.
- [6] M. H. Khan, M. Chaudhry, T. Tariq, Q.-U.-A. Fatima, and U. Izhar, "Fabrication and modelling of segway," in *2014 IEEE International Conference on Mechatronics and Automation (ICMA)*, 2014, pp. 280–285.
- [7] B. Das, S. Chakrabarti, P. R. Kasari, and A. Chakraborti, "Novel reverse regeneration technique of BLDC motor for capacitor charging," in *2014 International Conference on Control, Instrumentation, Energy and Communication (CIEC)*, 2014, pp. 246–253.
- [8] Y. S. Jeon, H. S. Mok, G. H. Choe, D. K. Kim, and J. S. Ryu, "A new simulation model of BLDC motor with real back EMF waveform," in *The 7th Workshop on Computers in Power Electronics, 2000. COMPEL 2000*, 2000, pp. 217–220.
- [9] B. Das, S. Chakrabarti, P. Ranjan, and K. Abanishwar, "Novel Reverse Regeneration Technique of BLDC Motor for Capacitor Charging," pp. 246–253, 2014.
- [10] H.E.A. Ibrahim, F.N. Hassan, A. O. Shomer, "Optimal PID control of a brushless DC motor using PSO and BF techniques" , in *Ain Shams Engineering Journal*, 2014, pp.391-398.
- [11] R. Kandiban, R. Arulmozhiyal, Speed Control of BLDC Motor Using Adaptive Fuzzy PID Controller", in *International Conference on Modelling, Optimisation and Computing*, 2012, pp.306-313 .
- [12] A. A. Portillo, M. Frye, and C. Qian, "Particle swarm optimization for PID tuning of a BLDC motor," in *IEEE International Conference on Systems, Man and Cybernetics, 2009. SMC 2009*, 2009, pp. 3917–3922.

ORIGINALITY REPORT

8%

SIMILARITY INDEX

6%

INTERNET SOURCES

6%

PUBLICATIONS

1%

STUDENT PAPERS

PRIMARY SOURCES

1

ojs.umsida.ac.id

Internet Source

2%

2

www.ijitee.org

Internet Source

1%

3

shodhganga.inflibnet.ac.in

Internet Source

1%

4

ujcontent.uj.ac.za

Internet Source

1%

5

www.ijser.org

Internet Source

1%

6

Supriya Kaul, Nitesh Tiwari, Shekhar Yadav, Awadhesh Kumar. "Comparative Analysis and Controller Design for BLDC Motor Using PID and Adaptive PID Controller", Recent Advances in Electrical & Electronic Engineering (Formerly Recent Patents on Electrical & Electronic Engineering), 2021

Publication

1%

7

uotechnology.edu.iq

Internet Source

1%

8

Submitted to The London College UCK

Student Paper

1 %

9

Guo, Q.. "A hybrid PSO-GD based intelligent method for machine diagnosis", Digital Signal Processing, 200607

Publication

1 %

Exclude quotes On

Exclude matches < 1%

Exclude bibliography On